

# Hall

FOOD EQUIPMENT

## Mincer Mixer 60 kg & 120 kg



Since 1945



**Standard inclusions:**

- 1 x 3 mm Mince Plate
- 1 x 5 mm Mince Plate
- 1 x 10 mm Mince Plate
- 1 x Knife Holder
- 2 x Insert
- 1 x Worm Puller
- 1 x Cleaning Brush

*Smart by Design, Built to Last*

Hall Food Equipment is an Australian owned and operated company and has been manufacturing Butchery Machines in Sydney since 1945. During this time we have successfully expanded our range of Australian made food processing equipment to include Mincers, Sausage Fillers, Mincer Mixers, Burger Press, Chopping Blocks, Preparation Tables & Pickle Pumps.

We pride ourselves on applying smart design, with quality built, durable high finished machines that will last for many years. We give personal attention to all our customers. Our Customer Service aim is to meet and exceed customer expectations through our quality products and true old fashioned customer service.

Intelligent design, and decades of experience are combined with a quality finish to produce the Hall Food Equipment Mincer Mixer. Hall Mincer Mixer will reward you by mincing and mixing meat and a variety of other products quickly, consistently and efficiently without the need for preservatives to make the product look and remain appealing.

Hall Mincer Mixer is a no compromise machines that comes standard with a stainless steel Barrel, stainless steel Worm and stainless steel Lock Ring. The hopper/tub has a high quality polished stainless steel finish to ensure that mince will not stick to the machine. The surface is easy to clean and is hygienic.

Hall Mincer Mixer is extremely versatile and can be used for a variety of different applications, including mincing & mixing all meat types, cheese, fruits, vegetables and nuts.

Hall Mincer Mixers complies with FSANZ, HACCP standards and is AS/NZS & AQIS Certified.

The highly polished interior hopper and the efficient and removable Mixing Paddle of the Mincer Mixer stops mince sticking to the machine resulting in less wasted product, and easier, quicker clean and better hygiene. The bottom line is more profit to the operator from a higher yield, reduced time to clean and a visually appealing & longer shelf life mince. These features are sure to please every quality & efficiency conscious operator and most importantly their customers.



Large Radius Corner ends  
Removable Stainless Steel Paddle



42 Size Cutting Head  
with 42 Size Worm



Stainless Steel Casters with Locks



Visually appealing & Long Shelf Life Mince without preservatives

Hall Mincer Mixer has two high quality independent electric motor driven reduction gear boxes - one to drive the mixing paddle and the other to drive the mincer worm. The high efficiency motors and quality gear boxes ensure economical, efficient and quiet operation for many years.

Hall Mincer Mixer does not compromise on quality & safety. A stainless steel grill type lid is designed for easy & safe operation. It provides full visibility and makes it easy & safe to pour flavourings/meats or liquids into the hopper without opening the lid. The grill type lid can be cleaned with a hose quickly and easily.

The lid has two safety latches and requires both hands to open the latches, ensuring safe operation. The lid is also fitted with a safety cut out switch which stops the machine automatically if the lid is lifted during operation.

Unlike machines with exposed bolts on the side covers, Hall Mincer Mixer do not have visible bolts and have snug, close fit panels. Meat and other product won't get stuck onto exposed bolts and or penetrate the close fitting panel skirts or covers, reducing the chance of foul odours and smells from unseen / hard to reach mince.

### Easy Clean = Better Hygiene

The hopper has large corner radius and is highly polished. Welding of the tub centers is barely visible. This minimises meat and bacteria sticking in any sharp corners/cavities and or poorly finished seam welding.

Hall 120 kg Mincer Mixer has special features to keep the temperature rise of the meat to a minimum during mincing process. To achieve this all food contact areas such as the tub & barrel are insulated from inside the machine to prevent any heat from motors reaching the meat. Further, it has a built in air cooling system to take away heat generated from motors and keep the inside of the machine cool. These features ensures a minimal rise in temperature of the mince, giving a better look and longer shelf life to the mince.

Hall Food machinery is very Reliable & Durable and given a bit of care will run trouble free for many years. All consumable parts & spares for our machines are reasonably priced & is readily available to minimise the cost of machine maintenance & down time.

Compare our quality, customer service, spare parts prices and availability with other makes of machine and you would realise the benefit of choosing TRUSTED HALL FOOD EQUIPMENT.

Contact us for a list of un-biased Hall Equipment users in your region/state.



**Stainless Steel Grill type Lid**

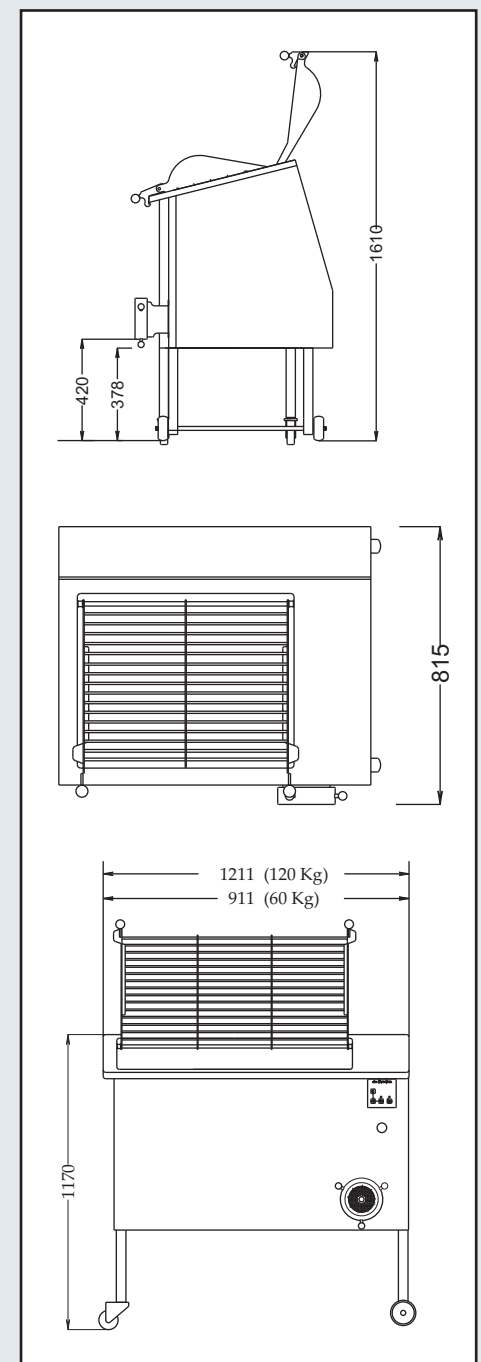

# FEATURES

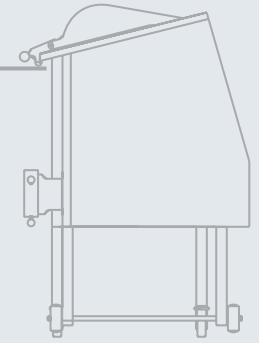

- Stainless Steel Body
- Stainless Steel Worm
- Stainless Steel Lock Ring
- Stainless Steel Exterior Skirt
- Stainless Steel Legs
- Stainless Steel Drive Shaft
- Stainless Steel Mixing Paddle
- Flawlessly Smooth, Polished Stainless Steel tub with almost no visible welding seam
- Removable Stainless Steel mixing arm for easy cleaning
- Computer Controlled Automatic Reciprocating Cycle Mixing action, via touch pad control adjustable 1-9 minute mix cycle
- Built in Motor Overload Protection
- 24 Volt Control circuits for additional user safety
- Ergonomic design, requires minimum of floor space, can be easily wheeled through standard door
- Supplied with 2 fixed wheels & 2 swivel lockable stainless steel castors
- Stainless Steel grill type Lid for clear visibility, safe & easy to pour liquids without any spill
- Advanced Safety Cut out Switch and Safety Latches on Lid
- Supplied with complete Cutting package including 3 Plates, 2 Blades, 1 Knife, Worm Puller & Cleaning Brush
- Reduces labour cost
- Low tub filling height
- Easy to clean – no visible bolts on side skirts – no place for meat to stick or hide
- Genuine full Single Cut 42 Size Cutting System with 42 Size Worm to give best cut and high efficiency, not like some other machines with 32 worm inside but with 42 head visible in front
- Full 42 Size worm to handle more meat with each turn hence less bruising, minimal rise in temperature of the meat, higher yield & longer shelf life of the mince
- All food contact areas such as tub and barrel are insulated to prevent heating of the meat for better quality mince & longer shelf life of the mince\*
- In-built Air-cooling system to prevent heating of the meat\*
- Cover plate in the bottom of the machine\*
- Electro polished Body, Worm & Lock Ring for efficient cool cut ensuring maximum product shelf life
- Electrical parts are enclosed in an IP 65 standard watertight box for safety
- 3 meter heavy duty power lead

\* This feature is only available in 120 kg Mincer Mixer

## TECHNICAL SPECIFICATIONS

	60 Kg	120 Kg		60 Kg	120 Kg
<b>Length</b>	950 mm	1210 mm	<b>Weight</b>	220 Kg (packed)	290 kg (packed)
<b>Height</b>	1200 mm	1200 mm	<b>Ship size</b>	1200x1200x1360 mm	1200x1300x1360 mm
<b>Width</b>	815 mm	815 mm	<b>Mix Motor</b>	1.1 kW	1.5 kW
<b>Fill Height</b>	1030 mm	1030 mm	<b>Mince Motor</b>	4 kW	5.5 kW
<b>Power Requirement</b>	415V, 3 phase 50Hz,20 Amp	415V, 3 phase 50Hz,20 Amp	<b>Tub Capacity</b>	125 L	190 L
<b>Full Load</b>	8.3 A/ph	11.5 A/ph	<b>Mix Capacity</b>	60 Kg	120 Kg

**Standard inclusions:-** 1 x 3mm #42 Mincer Plate, 1 x 5mm #42 Mincer Plate, 1 x 10mm #42 Mincer Plate, 2 Blade insert, 1 Knife holder, 1 Worm puller & 1 Cleaning brush

### OPTIONAL EXTRAS (must be specified with order)

- Full range of knives and plates
- Height can be changed at the time of placing order
- Foot Paddle Switch for hands free operation & with intelligent automatic safety cut-off.
- Second Speed Inverter

Specifications are subject to change without notice.

Manufactured and distributed by:-

**Hall Food Equipment**

A.B.N. 90 144 988 689

11 Distribution Place, SEVEN HILLS, NSW 2147

PHONE: +61 (0)2 9838 0799 FAX: +61 (0)2 9838 0399

E-mail: info@hallfood.com.au web: www.hallfood.com.au

**Hall**  
FOOD EQUIPMENT

Contact us for a list of un-biased Hall Equipment users in your region/state.